



Gjenvinning av plast ABC

www.protecscandinavia.com



 Plast avfall



 Tekstiler & fiberer



 Flasker











 Hushold & industri



 Bioplast og spesial plaster

Prosess steg 1

-  Grov sortering
-  Fin sortering
-  Shredding
-  Kverning
-  Vask (kaldt) og flyte separering
-  Vask (varmt)
-  Tørking
-  Mellomlagring (eller direkte til steg 2)

Prosess steg 2

-  Flakes sortering
-  Kondisjonering
-  Extrudering
-  Pelletering
-  Mellomlagring
-  Pakking

Fra avfall til plast granulat





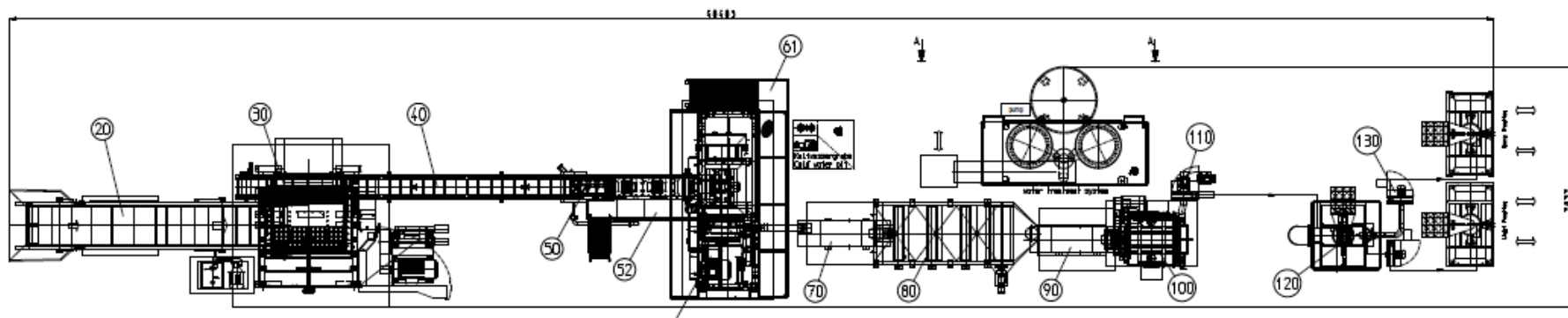
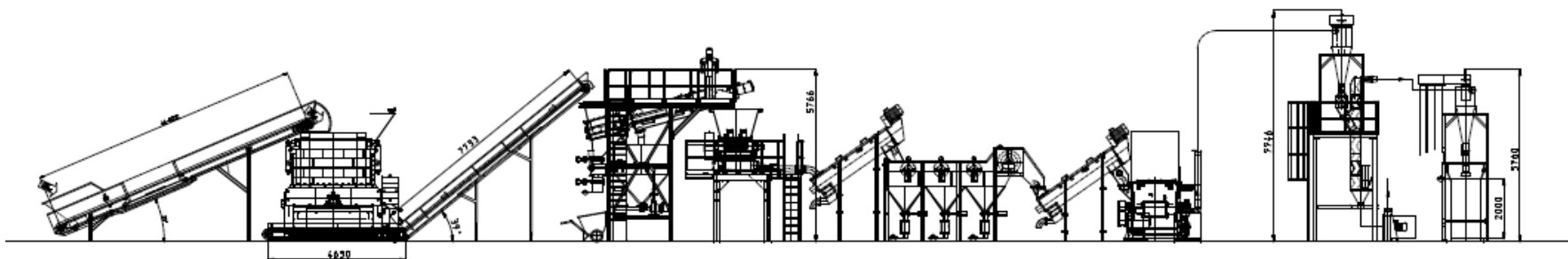

Vaske linje komponenter



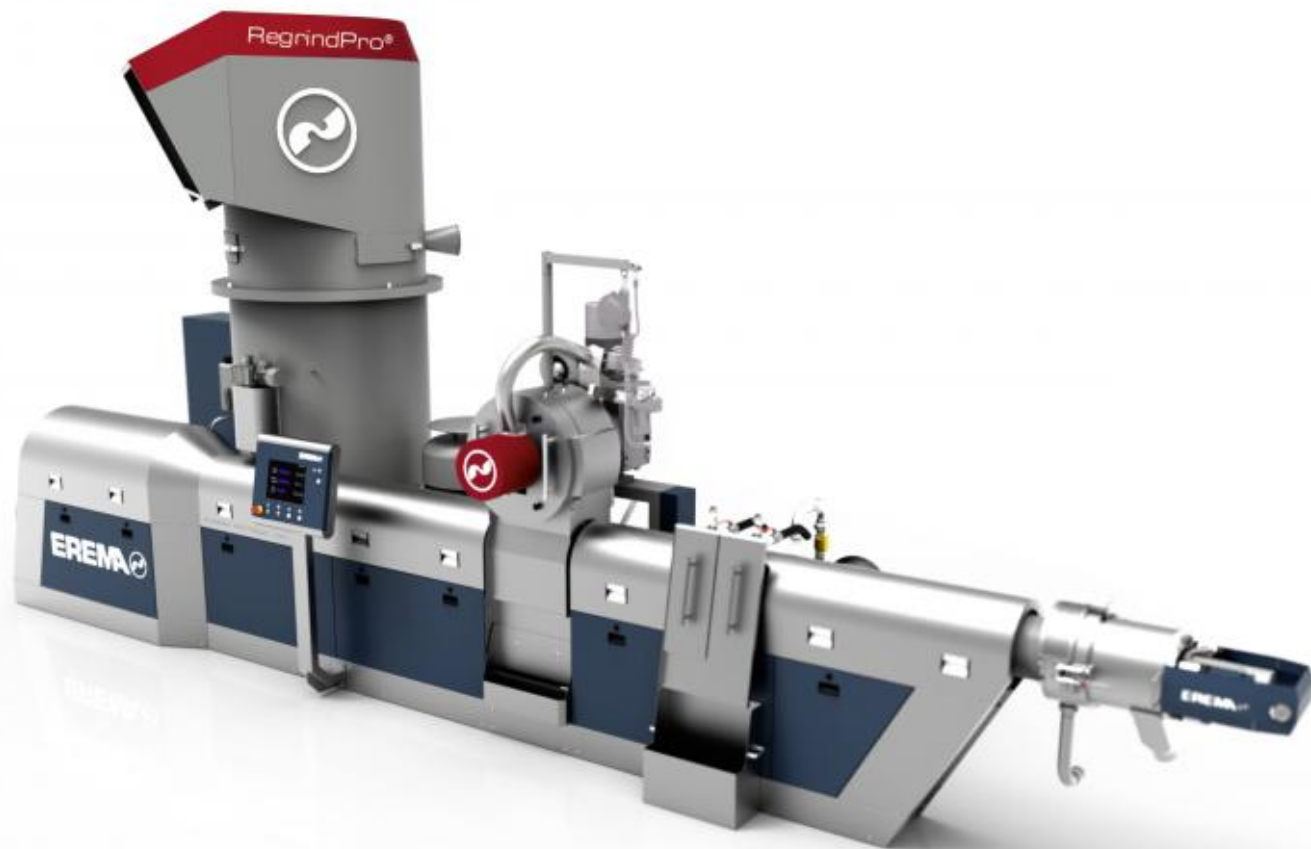









Ekstruderings komponenter



Hva, hvor mye, hvor raskt, hvor?

-  Hvilke typer polymerer skal gjenvinnes?
-  Hvor mye på års basis eller pr. time?
-  Hvor godt sortert er materialet når det leveres?
-  Hvor rent er materialet (forurensning av andre polymerer, papir...)?
-  Skal grov og fin sortering gjøres internt?
-  Skal vasking gjøres internt?
-  Skal ekstrudering og pelletering gjøres internt?
-  Skal anlegget ha flakes sortering?
-  Skal anlegget ha mellomagrings stasjoner?



Takk.

Join us!